

Pneumatic piston vibrators

FP serie

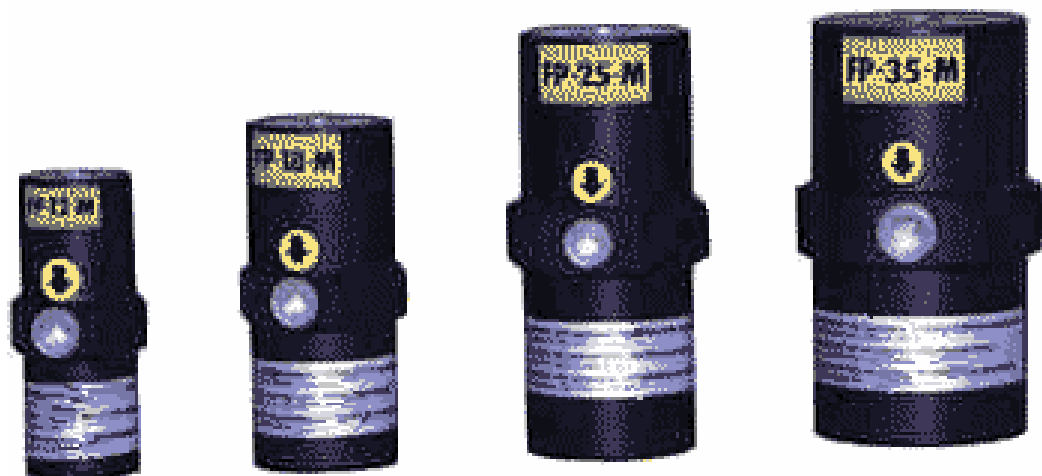

- Infinitely variable amplitude and frequency.
- Quiet and efficient.
- Explosion proof, light weight and compact.
- Designed to work continuously under the most arduous conditions.
- Particularly efficient for feeder applications.

Pneumatic piston vibrators. FP serie

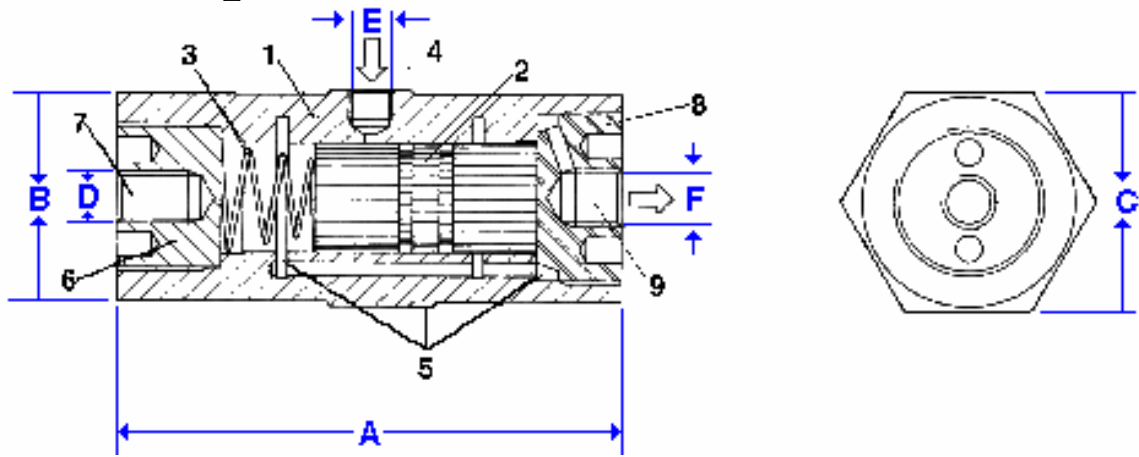

Description

- 1 - Hard anodised aluminum alloy body
- 2 - Leaded bronze piston
- 3 - Starter spring
- 4 - Air inlet
- 5 - Sound absorbing exhaust system
- 6 - Hard anodised aluminum alloy socket
- 7 - Threaded base for mounting
- 8 - Hard anodised aluminum alloy end cap
- 9 - Air outlet

Pneumatic piston vibrators. FP serie

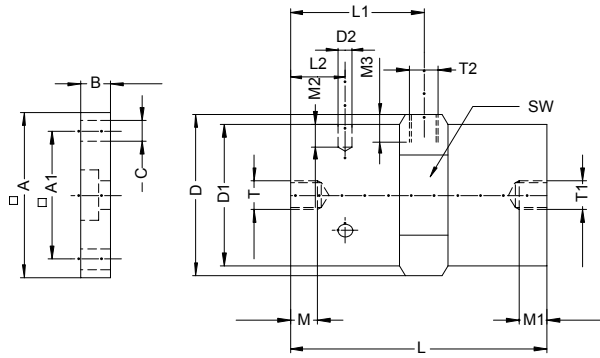

Dimensions and weights

Type	A	A1	B	C	D	D1	L	L1	L2	M	M1	M2	M3	T	T1	T2	SW	Body kg	Piston kg	Total kg
FP-12-S					37	31	71	35.5		11	11		7	M8	G1/8"	G1/8"	34	0.125	0.020	0.145
FP-12-M					37	31	81	40.5		11	11		7	M8	G1/8"	G1/8"	34	0.140	0.030	0.170
FP-12-L					37	31	94	47.0		11	11		7	M8	G1/8"	G1/8"	34	0.165	0.040	0.205
FP-18-S					45	40	81	40.5		13	11		7	M10	G1/8"	G1/8"	42	0.220	0.060	0.280
FP-18-M					45	40	94	47.0		13	11		7	M10	G1/8"	G1/8"	42	0.260	0.080	0.340
FP-18-L					45	40	109	54.5		13	11		7	M10	G1/8"	G1/8"	42	0.300	0.110	0.410
FP-25-S					53	48	98	41.5		15	11		7	M12	G1/4"	G1/8"	50	0.375	0.155	0.530
FP-25-M					53	48	116	60.5		15	11		7	M12	G1/4"	G1/8"	50	0.435	0.215	0.650
FP-25-L					53	48	136	70.5		15	11		7	M12	G1/4"	G1/8"	50	0.500	0.290	0.790
FP-35-S	90	72	20	9	69	58	98	41.5		15	11		9	M12	G1/4"	G1/4"	65	0.530	0.315	0.845
FP-35-M	90	72	20	9	69	58	116	60.5		15	11		9	M12	G1/4"	G1/4"	65	0.610	0.430	1.040
FP-35-L	90	72	20	9	69	58	136	70.5		15	11		9	M12	G1/4"	G1/4"	65	0.700	0.580	1.280
FP-50-M	90	72	20	9	84	84	157	81.5	31	15	11	12.5	9	M16	G1/4"	G1/4"		1.350	1.500	2.850
FP-60-M	110	90	20	9	94	94	157	81.5	31	15	11	12.5	9	M16	G1/4"	G1/4"		1.520	2.150	3.670

Technical characteristics

Type	Frequency vpm			Force Newton			Air consumption l / min.			Noise level	
	2 bar	4 bar	6 bar	2 bar	4 bar	6 bar	2 bar	4 bar	6 bar	dBA*	dBA**
FP-12-S	6200	7800	9300	34	70	92	0.8	7.5	25	57-61	
FP-12-M	5000	6000	6700	34	58	74	0.5	4	19	57-61	
FP-12-L	4000	4800	5400	32	58	81	1	3	20	58-60	
FP-18-S	5000	6400	7700	66	134	187	5	33	57	62-71	
FP-18-M	4000	5000	5900	68	134	188	4	28	52	61-67	
FP-18-L	3100	4000	4600	64	150	206	5	23	46	61-68	
FP-25-S	3600	4300	5500	126	270	416	13	54	93	70-75	61-67
FP-25-M	3000	3800	4200	142	364	504	23	50	87	73-75	62-66
FP-25-L	2400	3100	3700	186	392	594	18	62	93	72-75	60-65
FP-35-S	3800	4700	5800	294	668	1038	23	101	162	72-77	71-73
FP-35-M	3000	4000	4600	248	778	1080	24	83	141	74-78	70-73
FP-35-L	2400	3100	3600	282	680	1066	38	89	135	74-80	68-74
FP-50-M	1850	2250	2700	440	1040	1750	47	93	160	68-76	
FP-60-M	1800	2200	2550	650	1450	2300	55	110	190	70-76	

* With customary silencer

** With 1/4"-Free flow silencer

Data obtained with a Kistler 3-axis dynamometer on a heavy laboratory test block and displayed by Kistler control monitor (COMO). Frequency and force will decrease on a less rigid mount. Specifications subject to change without notice or obligation.